



8

7

6

PRODUCED BY AN AUTODESK EDUCATIONAL PRODUCT

5

4

3

2

1

NOTES:

REV	DATE	DRAWN BY	APPRVD BY	DESCRIPTION
A	10/06/08	B. BONNETT	B. BONNETT	INCREASED BOX HEIGHT BY 0.375"

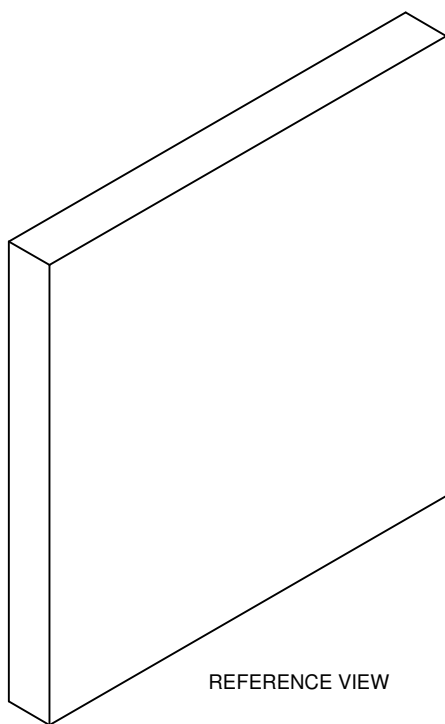

REFERENCE VIEW

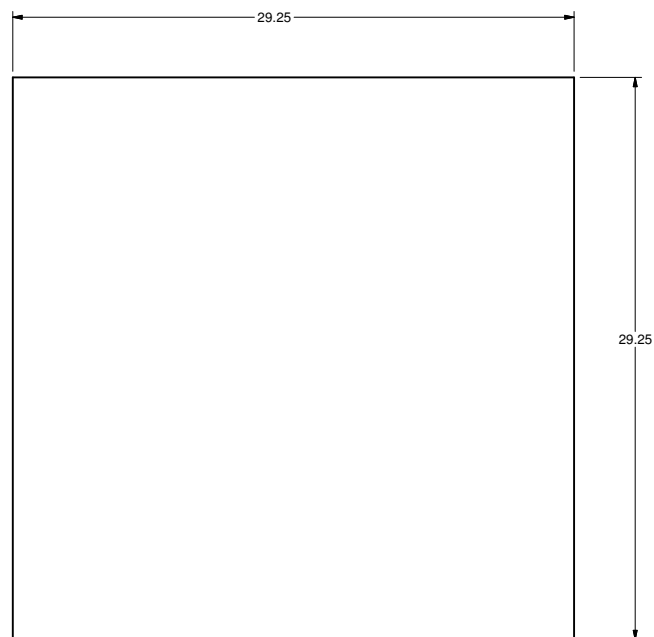

XPS-02-001P  
QTY:1

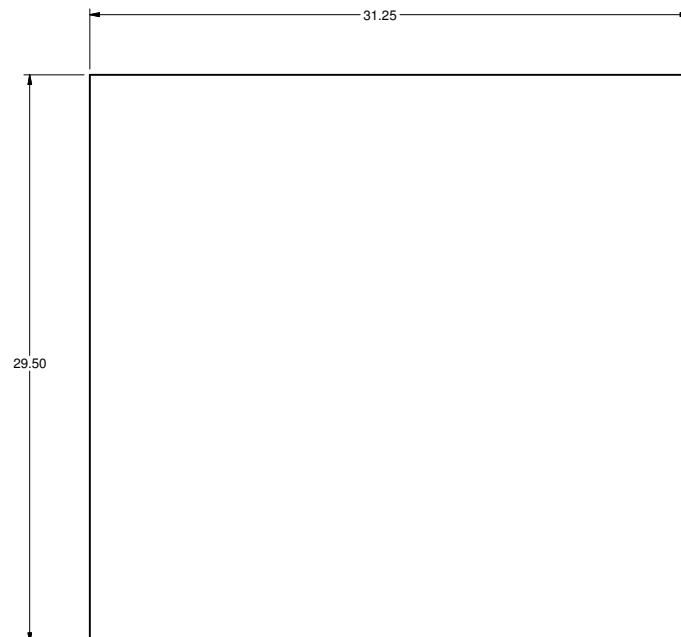

XPS-02-002P  
QTY:3

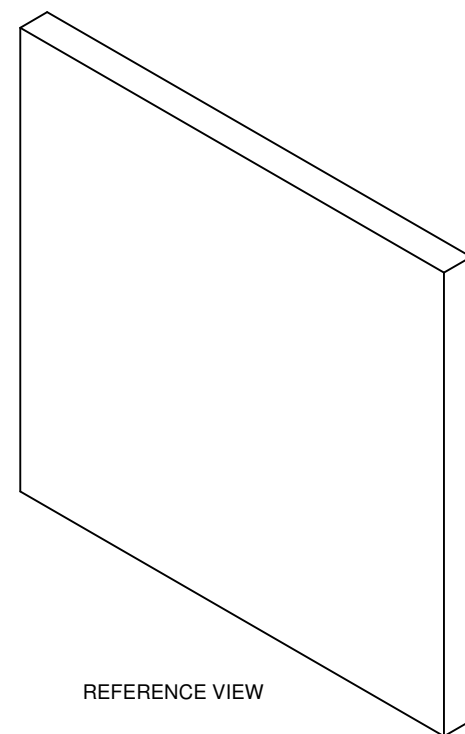
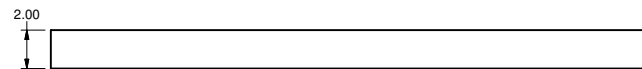
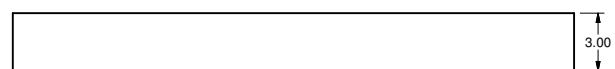

REFERENCE VIEW

UNLESS OTHERWISE SPECIFIED DIMENSIONS ARE IN INCHES		POLAR		IRIS/PASSCAL POLAR PROGRAM	
TOLERANCES - ANGLES ± 1°				SOCORRO, NM 87801	
4 PLACE DECIMALS (.XXXX) ±				DRAWN BY B. BONNETT	
3 PLACE DECIMALS (.XXX) ±				DATE 5/9/2008	
2 PLACE DECIMALS (.XX) ±				DESIGNED BY B. BONNETT	
1 PLACE DECIMALS (.X) ±				DATE 5/9/2008	
MATERIAL: EXTRUDED POLYSTYRENE		XPS-02-001A EXTRUDED POLYSTYRENE BOX FOR USE IN HARDIGG AL3434-2807		APPROVED BY	
FINISH:				DATE	
INVENTOR : XPS-02-001A.IDW		SHEET NUMBER 2 of 3		SCALE 1	
NEXT ASSEMBLY		DWG. TYPE		DRAWING NUMBER XPS-02-001A	

PRODUCED BY AN AUTODESK EDUCATIONAL PRODUCT

